



Standard Specification for Reinforced Autoclaved Aerated Concrete (AAC) Elements¹

This standard is issued under the fixed designation C1694; the number immediately following the designation indicates the year of original adoption or, in the case of revision, the year of last revision. A number in parentheses indicates the year of last reappraisal. A superscript epsilon (ϵ) indicates an editorial change since the last revision or reappraisal.

1. Scope

1.1 This specification covers reinforced solid elements manufactured from autoclaved aerated concrete (AAC), a cementitious product addressed by Specification C1693. The specification addresses dimensional tolerances, maximum limits for drying shrinkage, requirements for steel reinforcement, and shipping and handling.

1.2 The values stated in inch-pound units are to be regarded as standard. The values given in parentheses are mathematical conversions to SI units that are provided for information only and are not considered standard.

1.3 *This standard does not purport to address all of the safety concerns, if any, associated with its use. It is the responsibility of the user of this standard to establish appropriate safety and health practices and determine the applicability of regulatory limitations prior to use.*

2. Referenced Documents

2.1 *ASTM Standards:*²

A82/A82M Specification for Steel Wire, Plain, for Concrete Reinforcement (Withdrawn 2013)³

C1693 Specification for Autoclaved Aerated Concrete (AAC)

3. Classification

3.1 Reinforced AAC elements manufactured in accordance with this specification shall be classified according to their strength class.

4. Materials and Manufacture

4.1 Reinforced AAC elements manufactured in accordance with this specification shall be composed entirely of AAC material conforming to Specification C1693.

¹ This specification is under the jurisdiction of ASTM Committee C27 on Precast Concrete Products and is the direct responsibility of Subcommittee C27.60 on Precast Autoclaved Aerated Concrete.

Current edition approved Oct. 1, 2009. Published November 2009. DOI: 10.1520/C1694-09.

² For referenced ASTM standards, visit the ASTM website, www.astm.org, or contact ASTM Customer Service at service@astm.org. For *Annual Book of ASTM Standards* volume information, refer to the standard's Document Summary page on the ASTM website.

³ The last approved version of this historical standard is referenced on www.astm.org.

5. Physical Requirements

5.1 *Compressive Strength*—The compressive strength of the elements shall be determined according to Specification C1693, and shall conform to the requirements of Specification C1693 for the strength class in which the elements are classified.

5.2 *Dry Bulk Density*—The dry bulk density shall be determined according to Specification C1693, and shall conform to the requirements of Specification C1693 for the strength class in which the elements are classified.

5.3 *Drying Shrinkage*—The drying shrinkage shall be determined in accordance with Specification C1693, and the average drying shrinkage shall conform to the requirements of Specification C1693 for the strength class in which the elements are specified.

5.4 *Steel Reinforcement*—The properties of the steel reinforcement shall be determined in accordance with Specification A82/A82M and shall conform to the requirements of Table 1.

5.5 *Weld-Point Shear Strength*—The weld-point shear strength in the reinforcement shall be determined in accordance with Section 8 and shall conform to the requirements of Table 2.

5.6 *Concrete Cover of Steel Reinforcement*—The minimum concrete cover over the steel reinforcement shall be 0.375 in. (10 mm). The reinforcing steel shall receive a corrosion-resistant coating before casting.

NOTE 1—A cover greater than 0.375 in. (10 mm) may be required in fire resistant applications.

5.7 *Effectiveness of Corrosion Protection of Steel Reinforcement*—The effectiveness of the corrosion protection for the steel reinforcement shall be determined according to Section 7, and the resulting percentage of surface area that is corroded shall not exceed 5 % of the total surface area.

6. Dimensions and Permissible Variations

6.1 The dimensions of the reinforced elements shall be as specified by the AAC manufacturer. Allowable deviations from the specified element dimensions are provided in Table 3.

7. Corrosion Protection of Steel Reinforcement in AAC

7.1 *Apparatus:*

TABLE 1 Properties of Steel Reinforcement

Property	Minimum Characteristic	Value
Yield strength, min, ksi (MPa)	70 (485)	
Tensile strength, min, ksi (MPa)	80 (550)	
Reduction of area, min, %	30 ^A	

^A For material testing over 100 ksi (690 MPa) tensile strength, the reduction of area shall be not less than 25 %.

TABLE 2 Weld-Point Shear Strength for Steel Reinforcement

Diameter of the Longitudinal Reinforcement, in. (mm)	Minimum Shear Strength of the Joint, lbf (kN)
0.16 (4.0)	495 (2.20)
0.18 (4.5)	598 (2.66)
0.20 (5.0)	771 (3.43)
0.24 (6.0)	1113 (4.95)
0.28 (7.0)	1513 (6.73)
0.32 (8.0)	1987 (8.84)
0.35 (9.0)	2502 (11.13)
0.40 (10.0)	3091 (13.75)
0.43 (11.0)	3741 (16.64)
0.47 (12.0)	5339 (19.79)

TABLE 3 Dimensional Tolerances for Reinforced AAC Elements

Dimension	Floor, Roof, and Wall Panels
Length	±0.20 in. (±5 mm)
Width	±0.12 in. (±3 mm)
Thickness	±0.12 in. (±3 mm)
Tongue/groove alignment	±0.12 in. (±3 mm)

7.1.1 *Storage Container*, with dimensions sufficient to completely immerse AAC specimens.

7.2 *Test Specimens*—A test set shall consist of six test specimens having the dimensions 16 in. (400 mm) by width of the reinforced element by thickness of the reinforced element. The exposed surface areas of the steel reinforcement at each end of the test specimen shall be coated with the corrosion-protection compound and allowed to dry before testing. Three specimens are to be kept as reference specimens, and three specimens shall be tested.

7.3 Procedure:

7.3.1 *Reference Specimens*—Store the reference specimens in a room having a temperature of 59 to 68°F (15 to 20°C) and a relative humidity of 50 to 70 %.

7.3.2 *Test Specimens*—Immerse the test specimens in an aqueous sodium chloride solution, 3 % sodium chloride (NaCl) by mass, for periods of 2 h at intervals of three days. Repeat for a total of ten test cycles. When the specimens are not immersed in the sodium chloride solution, store them under the same conditions as the reference specimens. After completing the ten testing cycles, allow the specimens to air dry for 4 h.

7.3.3 *Inspection for Rust*—After completing the testing procedure, remove the autoclaved aerated concrete around the steel reinforcement in the reference specimen and the test specimens. By visual inspection, determine the area of rust covering the steel and express that area as a percentage of the total area of the specimen, using the following calculation:

$$A_r = \pi n_1 d_1 l_1 + \pi n_2 d_2 l_2 \text{ (mm}^2\text{)} \quad (1)$$

$$A_r = \sum w_i l_i \text{ (mm}^2\text{)} \quad (2)$$

$$P_r = 100 (A_r/A_t) \quad (3)$$

where:

A_r = total surface of reinforcement present in the specimen (mm²)

n_1 = number of longitudinal reinforcing rods,

d_1 = diameter of the longitudinal reinforcing rods (mm),

l_1 = length of the longitudinal reinforcing rods (mm),

n_2 = number of transverse reinforcing rods,

d_2 = diameter of transverse reinforcing rods (mm),

l_2 = length of the transverse reinforcing rods (mm),

A_r = area of rusted surface,

w_i = unrolled width of the corroded surface,

l_i = length of the corroded surface, and

P_r = percentage of surface area which is rusted.

The total area of corroded surface shall be reported as the average total area for the three test and the three reference specimens.

8. Weld-Point Shear Strength

8.1 *Apparatus*—Perform this test using the device shown in Fig. 1 or an equivalent device that can be fitted into a normal tension testing machine.

8.2 *Specimen*—Use a specimen of the shape shown in Fig. 2. Take specimens at random from welded mats of reinforcement that have not been coated with a corrosion-resistant compound. The bar with the largest diameter shall be selected as the test specimen. Do not fabricate special test specimens for this test, except for initial qualification of the welding device.

8.3 *Procedure*—Grip the specimen in the test fixture so that the tension bar is centrally located and rotation of the anchoring bar is prevented. Load at a rate not exceeding 112 lbf/s (0.5 kN/s).

8.4 *Test Results*—Report the following:

8.4.1 Nominal steel quality.

8.4.2 Diameter of the longitudinal bar (tensioned bar).

8.4.3 Diameter of the transverse bar (anchoring bar).

8.4.4 Ultimate shear force.

9. Shipping and Handling of Reinforced AAC Elements

9.1 Protect reinforced AAC elements from damage during shipping by placement on pallets or other supports, banding of the elements, placement of material between the elements, or any other method deemed appropriate by the AAC manufacturer. Handle reinforced AAC elements using lifting devices or clamps recommended by the AAC manufacturer.

10. Visual Inspection

10.1 All elements shall be sound and free of defects that would interfere with the proper placement of the unit or impair the strength or permanence of the construction. Minor imperfections incidental to the usual methods of manufacture, or resulting from customary methods of handling in shipment and delivery, shall not be deemed grounds for rejection.

11. Sampling and Testing

11.1 The purchaser or his authorized representative shall be accorded proper facilities to inspect and sample the elements at the place of manufacture from the lots ready for delivery.

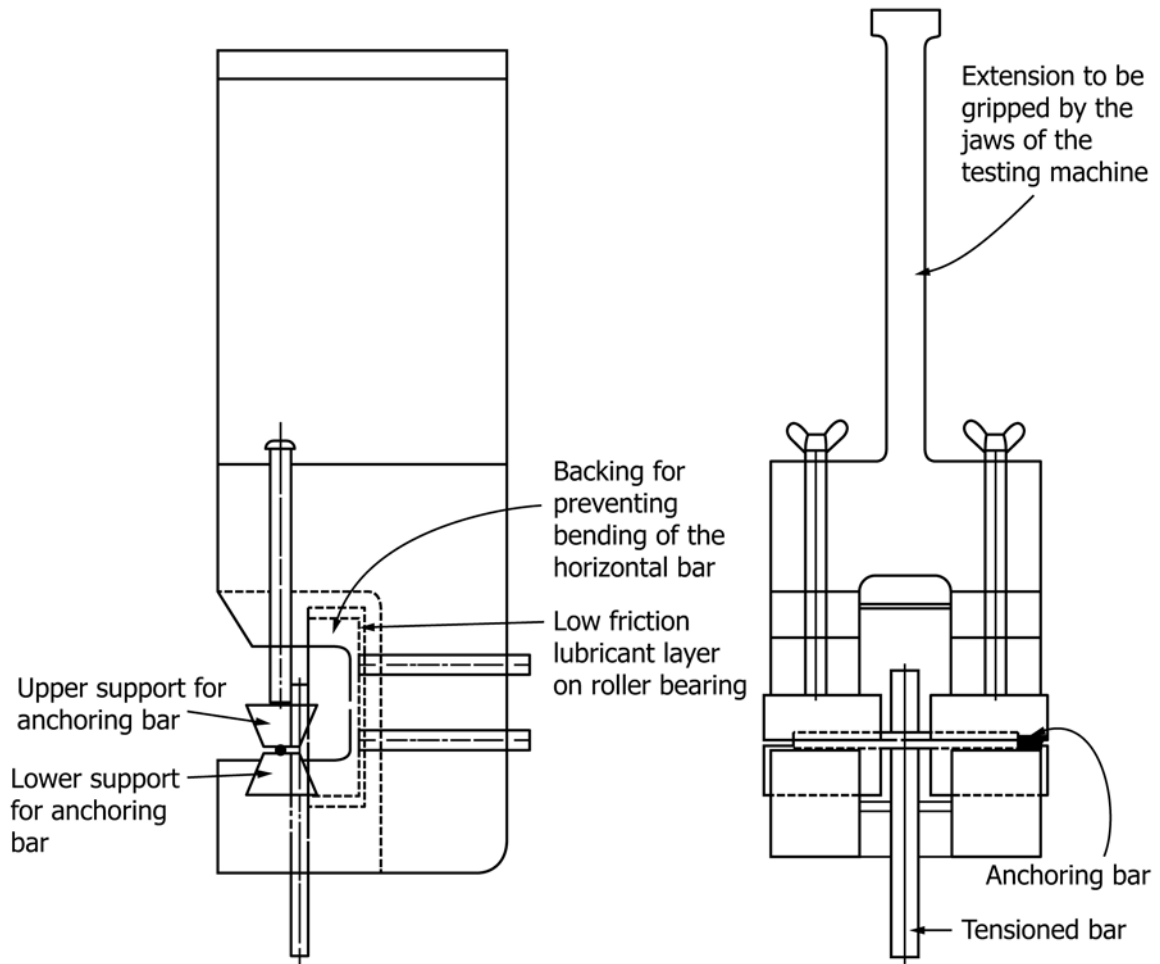

FIG. 1 Weld-Point Shear Strength Test Apparatus

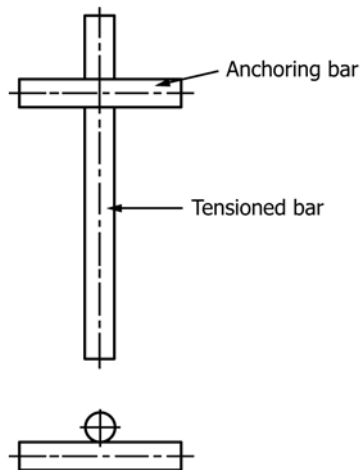

FIG. 2 Weld-Point Shear Strength Test Specimens

11.2 The elements shall be sampled and tested in accordance with test methods of this specification.

12. Rejection and Rehearing

12.1 If the shipment fails to conform to the specific requirements, the manufacturer shall be permitted to sort it, and new specimens shall be selected by the purchaser from the retained lot and tested at the expense of the manufacturer. If the second set of specimens fails to conform to the test requirements, the entire lot shall be rejected.

13. Expense of Tests

13.1 Except as specified in Section 12, and unless otherwise agreed, the expense of inspection and testing shall be borne by the purchaser.

14. Precision and Bias

14.1 The precision and bias of the test procedures described in Section 8, Section 9, and Section 10 are being determined and will be provided when sufficient data are available to indicate acceptable tolerances in repeatability and reproducibility.

15. Keywords

15.1 autoclaved aerated concrete (AAC); compressive strength; density; reinforced elements; reinforcement

ASTM International takes no position respecting the validity of any patent rights asserted in connection with any item mentioned in this standard. Users of this standard are expressly advised that determination of the validity of any such patent rights, and the risk of infringement of such rights, are entirely their own responsibility.

This standard is subject to revision at any time by the responsible technical committee and must be reviewed every five years and if not revised, either reapproved or withdrawn. Your comments are invited either for revision of this standard or for additional standards and should be addressed to ASTM International Headquarters. Your comments will receive careful consideration at a meeting of the responsible technical committee, which you may attend. If you feel that your comments have not received a fair hearing you should make your views known to the ASTM Committee on Standards, at the address shown below.

This standard is copyrighted by ASTM International, 100 Barr Harbor Drive, PO Box C700, West Conshohocken, PA 19428-2959, United States. Individual reprints (single or multiple copies) of this standard may be obtained by contacting ASTM at the above address or at 610-832-9585 (phone), 610-832-9555 (fax), or service@astm.org (e-mail); or through the ASTM website (www.astm.org). Permission rights to photocopy the standard may also be secured from the Copyright Clearance Center, 222 Rosewood Drive, Danvers, MA 01923, Tel: (978) 646-2600; <http://www.copyright.com/>